



MARINE SIGNAL LAMPS

S-8 and S-11 single contact, pre-focused marine signal lamps may be used on all PMAPI standard flasher/lampchanger units. Their rated life is 1000 hours. Their voltage and ampere ratings are listed in the table below.



API Part No	Volts	Amp	Filament	Envelope
4060 0085	6.2V	0.25	C-8	S-8
4060 0086	6.2V	0.46	C-8	S-8
4060 0087	6.2V	0.70	C-8	S-8
4060 0088	6.2V	0.92	C-8	S-8
4060 0200	12.0V	0.25	C-8	S-8
4060 0148	12.0V	0.50	CC-8	S-8
4060 0093	12.0V	0.55	C-8	S-8
4060 0094	12.0V	0.77	C-8	S-8
4060 0180	12.0V	1.00	CC-8	S-8
4060 0095	12.0V	1.15	C-8	S-8
4060 0182	12.0V	2.00	CC-8	S-8
4060 0097	12.0V	2.03	C-8	S-8
4060 0179	12.0V	3.00	CC-8	S-8
4060 0098	12.0V	3.05	C-8	S-11
4060 0217	12.0V	5.00	CC-8	S-11

HALOGEN LAMPS

Part No	Volts	Wattage
4060-0326	12v	9.0Ampere
4060-0368	12V	35W
4060-0346	12V	50W
4060-0347	12V	75W
4060-0348	12V	100W
4060-0343	24V	150W

INCANDESCENCE PERIOD OF ELECTRIC LAMPS

When calculating the effective intensity of a rhythmic electric light eclipsed by opening the circuit of a filament lamp, the light duration to be used is the period during which the circuit is closed, less the time taken for the filament to reach 90 per cent of full intensity. Nigrescence is assumed to be instantaneous at extreme range. The allowance can be read directly from the graph when the circuit has negligible resistance compared with the resistance of the hot filament.

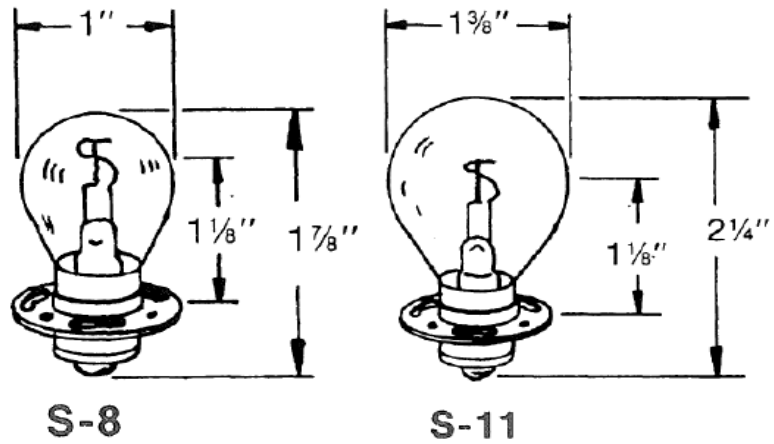
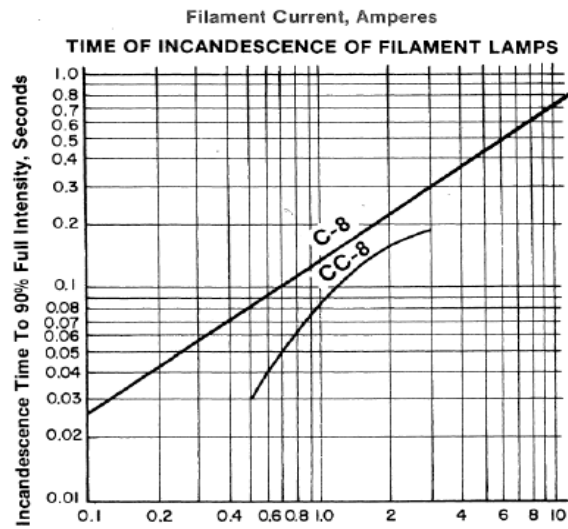

*Specifications subject to change without notice.

