

EM powerLED BASIC FX Ip 75 W

Combined emergency lighting LED driver



Product description

- _ Fixed output LED driver for mains operation
- _ Emergency lighting LED driver with manual test function
- _ For self-contained emergency lighting
- _ For LED modules with a forward voltage of 50 – 220 V
- _ For luminaire installation
- _ Low profile cross-section (21 x 30 mm)
- _ EM = Emergency
- _ 5 years guarantee (Conditions at <https://www.tridonic.com/manufacture-guarantee-conditions>)

Properties

- _ 6 – 75 W output power
- _ Constant current LED operation
- _ Adjustable output current between 100 and 400 mA via ready2mains Programmer or I-SELECT 2 plugs
- _ Integrated emergency lighting unit
- _ 1 or 3 h rated duration
- _ Automatic shutdown of output if LED load is out of range
- _ Green charge status display LED
- _ Electronic charge system
- _ Polarity reversal protection for battery
- _ Deep discharge protection
- _ Short-circuit-proof battery connection

Batteries

- _ High-temperature cells
- _ NiCd or NiMH batteries
- _ D, Cs or LAL cells
- _ 4 year design life
- _ 2 years guarantee (Conditions at <https://www.tridonic.com/manufacture-guarantee-conditions>)
- _ For battery compatibility refer to data sheet, battery selection

Website

<http://www.tridonic.com/89800598>

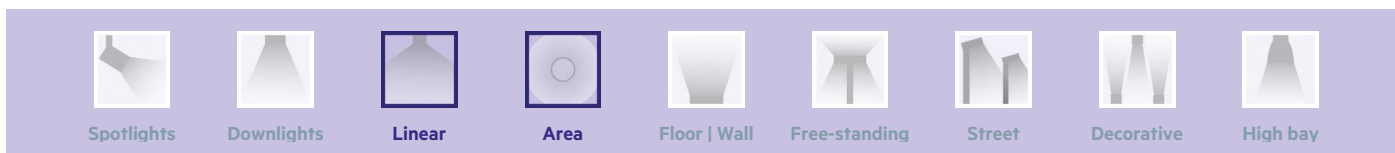

EM powerLED BASIC FX Ip 75 W

Combined emergency lighting LED driver

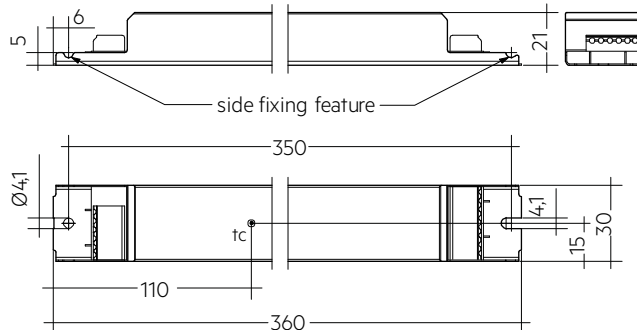
**Ordering data**

Type	Article number	Rated duration	Number of cells	Packaging, carton	Packaging, pallet	Weight per pc.
EM powerLED BASIC FX 213 Ip 75W 220V	89800598	1 h	3	10 pc(s).	600 pc(s).	0.245 kg
EM powerLED BASIC FX 214 Ip 75W 220V	89800599	1 h	4	10 pc(s).	600 pc(s).	0.245 kg
EM powerLED BASIC FX 215 Ip 75W 220V	89800600	1 h	5	10 pc(s).	600 pc(s).	0.245 kg
EM powerLED BASIC FX 233 Ip 75W 220V	89800601	3 h	3	10 pc(s).	600 pc(s).	0.245 kg
EM powerLED BASIC FX 234 Ip 75W 220V	89800602	3 h	4	10 pc(s).	600 pc(s).	0.245 kg
EM powerLED BASIC FX 235 Ip 75W 220V	89800603	3 h	5	10 pc(s).	600 pc(s).	0.245 kg

Technical data

Rated supply voltage AC	220 – 240 V
AC voltage range	198 – 264 V
Mains frequency	50 / 60 Hz
Typ. rated current (at 230 V, 50 Hz, full load) ^①	380 mA
Leakage current (at 230 V, 50 Hz, full load) ^①	< 250 µA
Max. input power	85 W
Typ. λ (at 230 V, 50 Hz, normal operation)	0.98
Overvoltage protection	320 V (for 48 h)
Battery charging time	< 24 h
U-OUT (including open- / short-circuit and double load)	280 V
Typ. input current in no-load operation 1 hr (charging)	16 mA
Typ. input current in no-load operation 3 hr (charging)	18 mA
Typ. input power in no-load operation 1 hr (charging)	2 W
Typ. input power in no-load operation 3 hr (charging)	2.4 W
In-rush current (peak / duration)	26 A / 280 µs
THD (at 230 V, 50 Hz, full load) ^①	< 10 %
Starting time	< 0.5 s from detection of emergency event
Starting time (mains off)	< 1.3 s
Starting time (stand-by)	< 250 ms
Turn off time (at 230 V, 50 Hz, full load)	< 50 ms
Output LF current ripple (< 120 Hz)	< 5 %
Output current tolerance	5 %
Ambient temperature t _a	-5 ... +50 °C
Max. casing temperature t _c	75 °C
Mains surge capability (between L - N)	1 kV
Mains surge capability (between L/N - PE)	2 kV
Surge voltage at output side (against PE)	2 kV
Dimensions L x W x H	360 x 30 x 21 mm
Mains voltage changeover threshold	According to EN 60598-2-22
Type of protection	IP20
Lifetime	up to 50,000 h
Guarantee (conditions at www.tridonic.com)	5 Year(s)

Approval marks

Standards

EN 61347-1, EN 61347-2-13, EN 61347-2-7, EN 62384, EN 55015, EN 61547, EN 61000-3-2, EN 60068-2-29, EN 60068-2-30, EN 60068-2-64, according to EN 50172, according to EN 60598-2-22

Specific technical data

Type	Number of battery cells	Output current ^①	Min. output voltage	Max. output voltage	Output power	Type. power consumption (at 230 V, 50 Hz, full load)	Type. current consumption (at 230 V, 50 Hz, full load)	λ (at 230 V, 50 Hz, full load)	I-SELECT resistor value ^⑤
Normal operation									
EM powerLED BASIC FX 213 lp 75W 220V	-	80 mA	75 V	220 V	20.0 W	20 W	100 mA	0.85C	-
EM powerLED BASIC FX 213 lp 75W 220V	-	100 mA	50 V	220 V	33.0 W	27 W	135 mA	0.90C	50.00 k Ω
EM powerLED BASIC FX 213 lp 75W 220V	-	150 mA	50 V	220 V	33.0 W	37 W	170 mA	0.95	33.33 k Ω
EM powerLED BASIC FX 213 lp 75W 220V	-	200 mA	50 V	220 V	44.0 W	49 W	220 mA	0.95	25.00 k Ω
EM powerLED BASIC FX 213 lp 75W 220V	-	250 mA	50 V	220 V	55.0 W	60 W	270 mA	0.97	20.00 k Ω
EM powerLED BASIC FX 213 lp 75W 220V	-	300 mA	50 V	220 V	66.0 W	71 W	320 mA	0.97	16.67 k Ω
EM powerLED BASIC FX 213 lp 75W 220V	-	350 mA	50 V	214 V	75.0 W	82 W	360 mA	0.98	14.29 k Ω
EM powerLED BASIC FX 213 lp 75W 220V	-	400 mA	50 V	188 V	75.0 W	82 W	370 mA	0.98	0.00 k Ω
EM powerLED BASIC FX 214 lp 75W 220V	-	80 mA	75 V	220 V	20.0 W	20 W	100 mA	0.85C	-
EM powerLED BASIC FX 214 lp 75W 220V	-	100 mA	50 V	220 V	33.0 W	27 W	135 mA	0.90C	50.00 k Ω
EM powerLED BASIC FX 214 lp 75W 220V	-	150 mA	50 V	220 V	33.0 W	37 W	170 mA	0.95	33.33 k Ω
EM powerLED BASIC FX 214 lp 75W 220V	-	200 mA	50 V	220 V	44.0 W	49 W	220 mA	0.95	25.00 k Ω
EM powerLED BASIC FX 214 lp 75W 220V	-	250 mA	50 V	220 V	55.0 W	60 W	270 mA	0.97	20.00 k Ω
EM powerLED BASIC FX 214 lp 75W 220V	-	300 mA	50 V	220 V	66.0 W	71 W	320 mA	0.97	16.67 k Ω
EM powerLED BASIC FX 214 lp 75W 220V	-	350 mA	50 V	214 V	75.0 W	82 W	360 mA	0.98	14.29 k Ω
EM powerLED BASIC FX 214 lp 75W 220V	-	400 mA	50 V	188 V	75.0 W	82 W	370 mA	0.98	0.00 k Ω
EM powerLED BASIC FX 215 lp 75W 220V	-	80 mA	75 V	220 V	20.0 W	20 W	100 mA	0.85C	-
EM powerLED BASIC FX 215 lp 75W 220V	-	100 mA	50 V	220 V	33.0 W	27 W	135 mA	0.90C	50.00 k Ω
EM powerLED BASIC FX 215 lp 75W 220V	-	150 mA	50 V	220 V	33.0 W	37 W	170 mA	0.95	33.33 k Ω
EM powerLED BASIC FX 215 lp 75W 220V	-	200 mA	50 V	220 V	44.0 W	49 W	220 mA	0.95	25.00 k Ω
EM powerLED BASIC FX 215 lp 75W 220V	-	250 mA	50 V	220 V	55.0 W	60 W	270 mA	0.97	20.00 k Ω
EM powerLED BASIC FX 215 lp 75W 220V	-	300 mA	50 V	220 V	66.0 W	71 W	320 mA	0.97	16.67 k Ω
EM powerLED BASIC FX 215 lp 75W 220V	-	350 mA	50 V	214 V	75.0 W	82 W	360 mA	0.98	14.29 k Ω
EM powerLED BASIC FX 215 lp 75W 220V	-	400 mA	50 V	188 V	75.0 W	82 W	370 mA	0.98	0.00 k Ω
EM powerLED BASIC FX 233 lp 75W 220V	-	80 mA	75 V	220 V	20.0 W	20 W	100 mA	0.85C	-
EM powerLED BASIC FX 233 lp 75W 220V	-	100 mA	50 V	220 V	33.0 W	27 W	135 mA	0.90C	50.00 k Ω
EM powerLED BASIC FX 233 lp 75W 220V	-	150 mA	50 V	220 V	33.0 W	37 W	170 mA	0.95	33.33 k Ω
EM powerLED BASIC FX 233 lp 75W 220V	-	200 mA	50 V	220 V	44.0 W	49 W	220 mA	0.95	25.00 k Ω
EM powerLED BASIC FX 233 lp 75W 220V	-	250 mA	50 V	220 V	55.0 W	60 W	270 mA	0.97	20.00 k Ω
EM powerLED BASIC FX 233 lp 75W 220V	-	300 mA	50 V	220 V	66.0 W	71 W	320 mA	0.97	16.67 k Ω
EM powerLED BASIC FX 233 lp 75W 220V	-	350 mA	50 V	214 V	75.0 W	82 W	360 mA	0.98	14.29 k Ω
EM powerLED BASIC FX 233 lp 75W 220V	-	400 mA	50 V	188 V	75.0 W	82 W	370 mA	0.98	0.00 k Ω
EM powerLED BASIC FX 234 lp 75W 220V	-	80 mA	75 V	220 V	20.0 W	20 W	100 mA	0.85C	-
EM powerLED BASIC FX 234 lp 75W 220V	-	100 mA	50 V	220 V	33.0 W	27 W	135 mA	0.90C	50.00 k Ω
EM powerLED BASIC FX 234 lp 75W 220V	-	150 mA	50 V	220 V	33.0 W	37 W	170 mA	0.95	33.33 k Ω
EM powerLED BASIC FX 234 lp 75W 220V	-	200 mA	50 V	220 V	44.0 W	49 W	220 mA	0.95	25.00 k Ω
EM powerLED BASIC FX 234 lp 75W 220V	-	250 mA	50 V	220 V	55.0 W	60 W	270 mA	0.97	20.00 k Ω
EM powerLED BASIC FX 234 lp 75W 220V	-	300 mA	50 V	220 V	66.0 W	71 W	320 mA	0.97	16.67 k Ω
EM powerLED BASIC FX 234 lp 75W 220V	-	350 mA	50 V	214 V	75.0 W	82 W	360 mA	0.98	14.29 k Ω
EM powerLED BASIC FX 234 lp 75W 220V	-	400 mA	50 V	188 V	75.0 W	82 W	370 mA	0.98	0.00 k Ω
EM powerLED BASIC FX 235 lp 75W 220V	-	80 mA	75 V	220 V	20.0 W	20 W	100 mA	0.85C	-
EM powerLED BASIC FX 235 lp 75W 220V	-	100 mA	50 V	220 V	33.0 W	27 W	135 mA	0.90C	50.00 k Ω
EM powerLED BASIC FX 235 lp 75W 220V	-	150 mA	50 V	220 V	33.0 W	37 W	170 mA	0.95	33.33 k Ω
EM powerLED BASIC FX 235 lp 75W 220V	-	200 mA	50 V	220 V	44.0 W	49 W	220 mA	0.95	25.00 k Ω
EM powerLED BASIC FX 235 lp 75W 220V	-	250 mA	50 V	220 V	55.0 W	60 W	270 mA	0.97	20.00 k Ω
EM powerLED BASIC FX 235 lp 75W 220V	-	300 mA	50 V	220 V	66.0 W	71 W	320 mA	0.97	16.67 k Ω
EM powerLED BASIC FX 235 lp 75W 220V	-	350 mA	50 V	214 V	75.0 W	82 W	360 mA	0.98	14.29 k Ω
EM powerLED BASIC FX 235 lp 75W 220V	-	400 mA	50 V	188 V	75.0 W	82 W	370 mA	0.98	0.00 k Ω
Emergency operation									
EM powerLED BASIC FX 213 lp 75W 220V	3	-	50 V	220 V	2.5 W	-	-	-	-
EM powerLED BASIC FX 214 lp 75W 220V	4	-	50 V	220 V	3.5 W	-	-	-	-
EM powerLED BASIC FX 215 lp 75W 220V	5	-	50 V	220 V	4.5 W	-	-	-	-
EM powerLED BASIC FX 233 lp 75W 220V	3	-	50 V	220 V	2.5 W	-	-	-	-
EM powerLED BASIC FX 234 lp 75W 220V	4	-	50 V	220 V	3.5 W	-	-	-	-
EM powerLED BASIC FX 235 lp 75W 220V	5	-	50 V	220 V	4.5 W	-	-	-	-

① Depending on the selected output current.

② The table only lists a number of possible operating points but does not cover each single point. The output current can be set within the total value range in 1-mA-steps. Output current is mean value.

③ Output current is mean value.

④ Output voltage range defined in normal operation.

⑤ Not compatible with I-SELECT (generation 1). Calculated resistor value.

Test switch EM2

Accessory



Product description

- _ For connection to the emergency lighting unit
- _ For checking the device function
- _ Dielectric strength: 1,500 V AC for 60 seconds

Website

<http://www.tridonic.com/89805277>



Ordering data

Type	Article number	Packaging, bag	Packaging, carton	Weight per pc.
Test switch EM 2	89805277	25 pc(s).	600 pc(s).	0.009 kg

Approval marks

RoHS

Status indication green LED EM

Accessory



Product description

- _ A green LED indicates that charging current is flowing into the battery

Website

<http://www.tridonic.com/89899605>



Ordering data

Type	Article number	Packaging, bag	Packaging, carton	Weight per pc.
LED EM green	89899605	25 pc(s).	200 pc(s).	0.011 kg
LED EM green, ultra high brightness	89899756	25 pc(s).	200 pc(s).	0.012 kg

Approval marks

RoHS

I-SELECT 2 PLUG PRE / EXC

Accessory

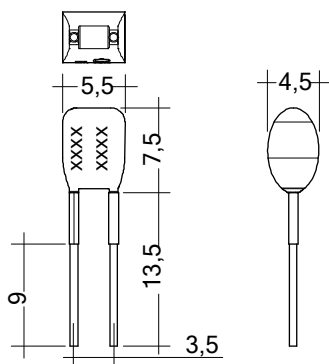
**Product description**

- _ Ready-for-use resistor to set output current value
- _ Compatible with LED driver featuring I-select 2 interface; not compatible with I-SELECT (generation 1)
- _ Resistor is base insulated
- _ Resistor power 0.25 W
- _ Current tolerance $\pm 2\%$ additional to output current tolerance
- _ Compatible with LED driver series PRE and EXC

Example of calculation

- _ $R [k\Omega] = 5 V / I_{out} [mA] \times 1000$
- _ E96 resistor value used
- _ Resistor value tolerance $\leq 1\%$; resistor power $\geq 0.1 W$; base insulation necessary
- _ When using a resistor value beyond the specified range, the output current will automatically be set to the minimum value (resistor value too big), respectively to the maximum value (resistor value too small)

Website

<http://www.tridonic.com/28001101>

**Ordering data**

Type	Article number	Colour	Marking	Current	Resistor value	Packaging, bag	Weight per pc.
I-SELECT 2 PLUG 125MA BL	28001101	Blue	0125 mA	125 mA	40.20 k Ω	10 pc(s).	0.001 kg
I-SELECT 2 PLUG 150MA BL	28001102	Blue	0150 mA	150 mA	33.20 k Ω	10 pc(s).	0.001 kg
I-SELECT 2 PLUG 200MA BL	28001104	Blue	0200 mA	200 mA	24.90 k Ω	10 pc(s).	0.001 kg
I-SELECT 2 PLUG 225MA BL	28001105	Blue	0225 mA	225 mA	22.10 k Ω	10 pc(s).	0.001 kg
I-SELECT 2 PLUG 250MA BL	28001106	Blue	0250 mA	250 mA	20.00 k Ω	10 pc(s).	0.001 kg
I-SELECT 2 PLUG 275MA BL	28001107	Blue	0275 mA	275 mA	18.20 k Ω	10 pc(s).	0.001 kg
I-SELECT 2 PLUG 300MA BL	28001108	Blue	0300 mA	300 mA	16.50 k Ω	10 pc(s).	0.001 kg
I-SELECT 2 PLUG 325MA BL	28001109	Blue	0325 mA	325 mA	15.40 k Ω	10 pc(s).	0.001 kg
I-SELECT 2 PLUG 350MA BL	28001110	Blue	0350 mA	350 mA	14.30 k Ω	10 pc(s).	0.001 kg
I-SELECT 2 PLUG 375MA BL	28001111	Blue	0375 mA	375 mA	13.30 k Ω	10 pc(s).	0.001 kg
I-SELECT 2 PLUG 400MA BL	28001112	Blue	0400 mA	400 mA	12.40 k Ω	10 pc(s).	0.001 kg
I-SELECT 2 PLUG MAX BL	28001099	Blue	MAX	MAX	0.00 k Ω	10 pc(s).	0.001 kg

1. Standards

- EN 61347-1
- EN 61347-2-13
- EN 61347-2-7
- EN 62384
- EN 55015
- EN 61547
- EN 61000-3-2
- EN 60068-2-29
- EN 60068-2-30
- EN 60068-2-64
- according to EN 50172
- according to EN 60598-2-22

2. Thermal data

2.1 Expected Lifetime

Average lifetime 50,000 hours under rated conditions with a failure rate of less than 10 %. Average failure rate of 0.2 % per 1000 operating hours.

Expected lifetime					
Type	Output power	ta	40 °C	50 °C	55 °C
	< 40 W	tc	56 °C	66 °C	71 °C
		Lifetime	> 100,000 h	70,000 h	50,000 h
EM powerLED BASIC FX 2xx Ip 75W 220V	40 – 60 W	tc	60 °C	70 °C	–
		Lifetime	> 100,000 h	60,000 h	–
	> 60 – 75 W	tc	65 °C	75 °C	–
		Lifetime	> 100,000 h	50,000 h	–

The EM powerLED is designed for a lifetime stated above under reference conditions and with a failure probability of less than 10 %.

The relation of tc to ta temperature depends also on the luminaire design.

If the measured tc temperature is approx. 5 K below tc max., ta temperature should be checked and eventually critical components (e.g. ELCAP) measured. Detailed information on request.

3. Installation / Wiring

3.1 Wiring diagrams

Wiring diagram EM powerLED BASIC FX without sensor

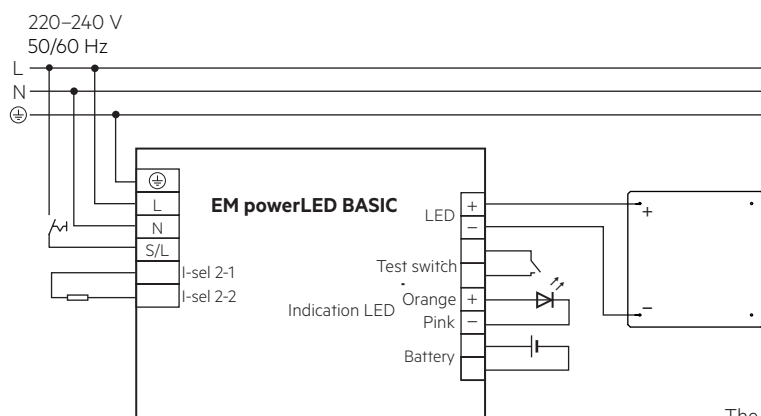

The connected LED module will be used for mains and emergency operation.

The mains power must be removed before changing the LED load.

Secondary switching of LEDs is not allowed and may cause damage to the LEDs. The hot plug-in of LEDs during normal operation may result in high current peaks.

3.2 Wiring type and cross section

Solid wire with a cross section of 0.5 – 1.5 mm². Strip 8 – 9 mm of insulation from the cables to ensure perfect operation of terminals.

LED module/LED Driver/supply

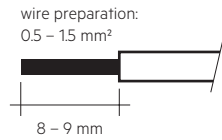

3.3 Loose wiring

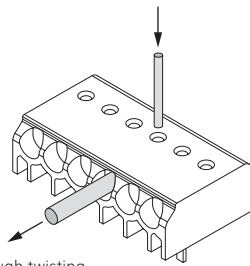

Loosen wire through twisting and pulling or using a Ø 1 mm release tool

Maximum lead length

LED	3 m
status indication LED	1 m
batteries	1 m

3.4 Wiring guidelines

- The output to the LED is DC but has high frequency content, which should be considered for good EMC compliance.
- LED leads should be separated from the mains connections and wiring for good EMC performance.
- Maximum lead length on the LED terminals is 3 m. For a good EMC performance keep the LED wiring as short as possible.
- The secondary wires (LED module) should be routed in parallel to ensure good EMC performance.
- Maximum lead length for the Test switch and Indicator LED connection is 1 m. The test switch and Indicator LED wiring should be separated from the LED leads to prevent noise coupling.
- Battery leads are specified with 0.5 mm cross section and a length of 1.3 m.
- To avoid the damage of the control gear, the wiring must be protected against short circuits to earth (sharp edged metal parts, metal cable clips, louver, etc.).

To ensure that a luminaire containing LED emergency units complies with EN 55015 for radio frequency conducted interference in both normal and emergency mode it is essential to follow good practice in the wiring layout.

Within the luminaire the switched and unswitched 50 Hz supply wiring must be routed as short as possible and be kept as far away as possible from the LED leads. Through wiring may affect the emc performance of the luminaire.

The length of LED leads must not be exceeded.

The output current depends on the forward voltage and the tolerance of the LED modules.

4. Mechanical data

4.1 Housing properties

- Low-profile metal casing with white cover
- Type of protection IP 20

4.2 Mechanical data accessories

LED status indicator

- Green
- Mounting hole 6.5 mm diameter, 1 – 1.6 mm thickness
- Lead length 0.8 m
- Insulation rating: 90 °C

Test switch

- Mounting hole 7.0 mm diameter
- Lead length 0.55 m

Battery leads

- Quantity: 1 red and 1 black
- Length: 1.3 m
- Wire type: 0.5 mm² solid conductor
- Insulation rating: 90 °C

Battery end termination

Push on 4.8 mm receptacle to suit battery spade fitted with insulating cover or plug connection.

Module end termination

8.0 mm stripped insulation

Two-piece batteries are supplied with a 200 mm lead with 4.8 mm receptacle at each end and insulating covers to connect the separate sticks together.

5. Electrical values

5.1 Maximum loading of automatic circuit breakers

Automatic circuit breaker type	C10	C13	C16	C20	B10	B13	B16	B20	Inrush current	
Installation Ø	1.5 mm ²	1.5 mm ²	2.5 mm ²	2.5 mm ²	1.5 mm ²	1.5 mm ²	2.5 mm ²	2.5 mm ²	I _{max}	time
EM powerLED BASIC FX 2xx Ip 75W 220V	12	18	24	28	6	9	12	14	25.8 A	280 µs

Calculation uses typical values from ABB series S200 as a reference.

Actual values may differ due to used circuit breaker types and installation environment.

5.2 Insulation matrix

	Mains	Switched Live	Battery, LED, Test switch, Indicator LED	I-SELECT 2
Mains	–	•	••	•
Switched Live	•	–	••	•
Battery, LED, Test switch, Indicator LED	••	••	–	••
I-SELECT 2	•	•	••	–

• Represents basic insulation

•• Represents double or reinforced insulation

Insulate the battery, LED, test switch and indicator LED in the luminaire according to the U-OUT rating of the LED Driver.

5.3 Typ. LED current/voltage characteristics

The LED current in emergency mode is automatically adjusted by the EM powerLED module based on the total forward voltage of the LED modules connected and the associated battery. The start of the LED in emergency mode does not result in a current peak.

EM powerLED BASIC FX 213 / 233 Ip 75W 220V
 Article number: 89800598 / 89800601
 3.6 V battery voltage
 850 – 960 mA battery discharge current (tolerance)

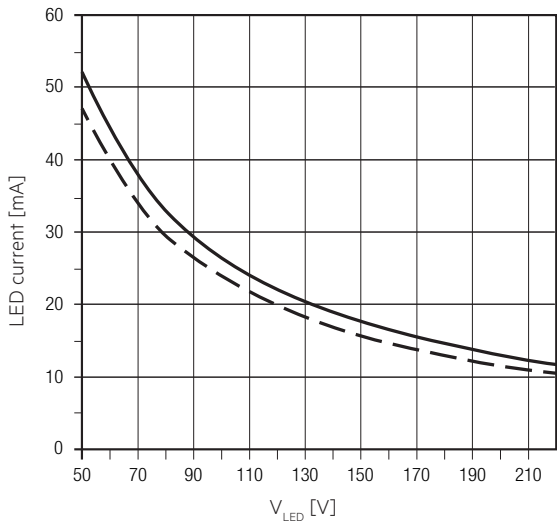

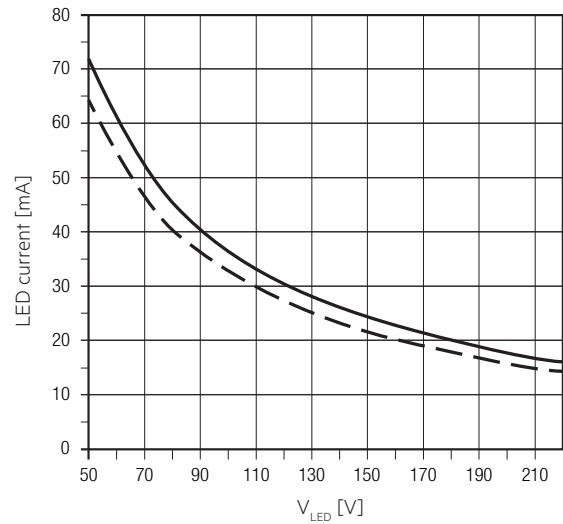

EM powerLED BASIC FX 214 / 234 Ip 75W 220V
 Article number: 89800599 / 89800602
 4.8 V battery voltage
 850 – 960 mA battery discharge current (tolerance)

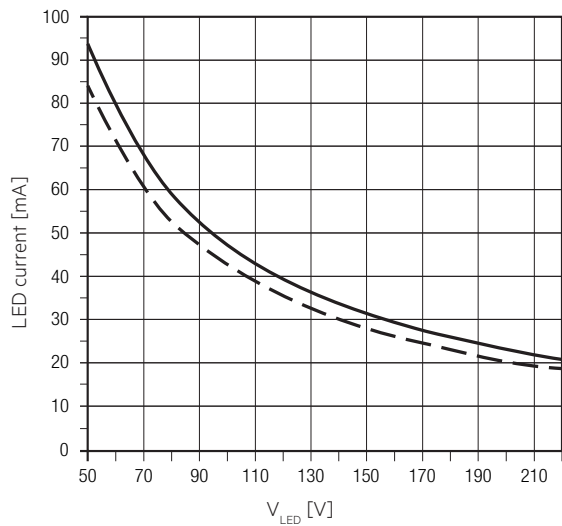

EM powerLED BASIC FX 215 / 235 Ip 75W 220V
 Article number: 89800600 / 89800603
 6.0 V battery voltage
 850 – 960 mA battery discharge current (tolerance)



 LED current at nominal battery voltage and min. battery discharge current
 LED current at nominal battery voltage and max. battery discharge current

5.4 Operating window

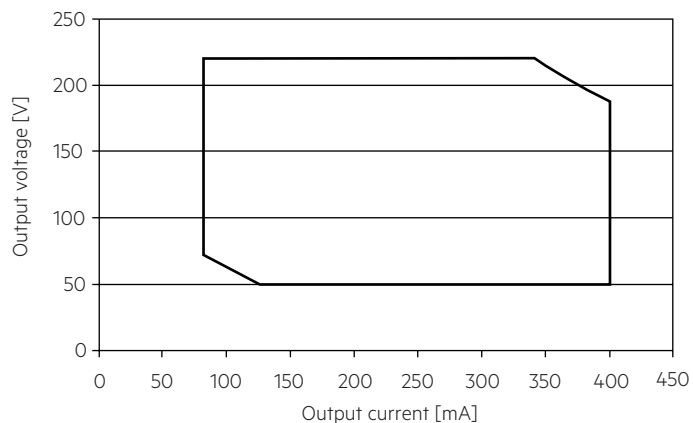

— Operating window 100 %

Make sure that the LED Driver is operated within the given window under all operating conditions. Coming below the specified minimum output voltage of the LED Driver may cause the device to shut-down.

5.5 Efficiency vs load

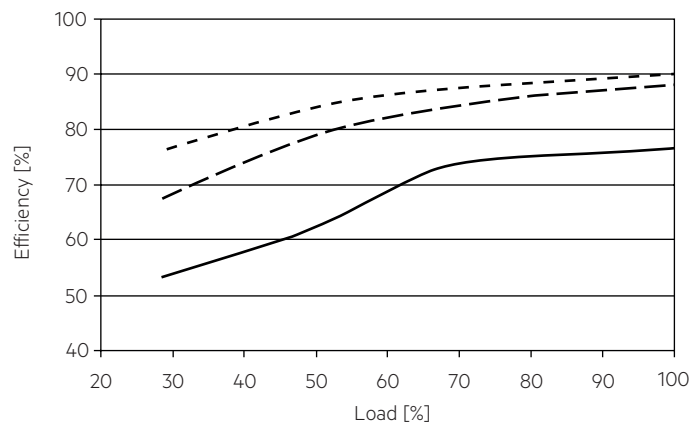

5.6 Power factor vs load

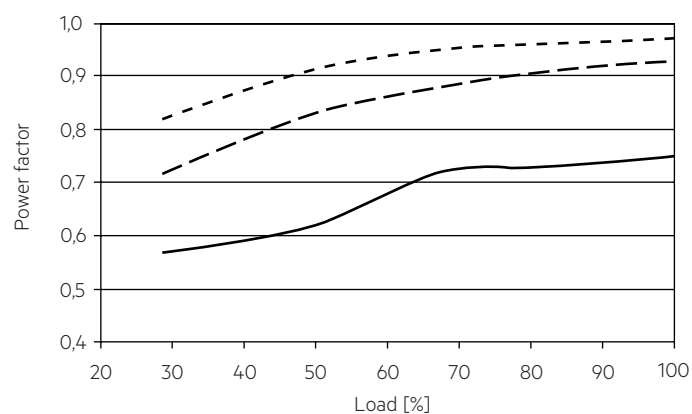

5.7 THD vs load

THD without harmonic < 5 mA or 0.6 % of the input current:

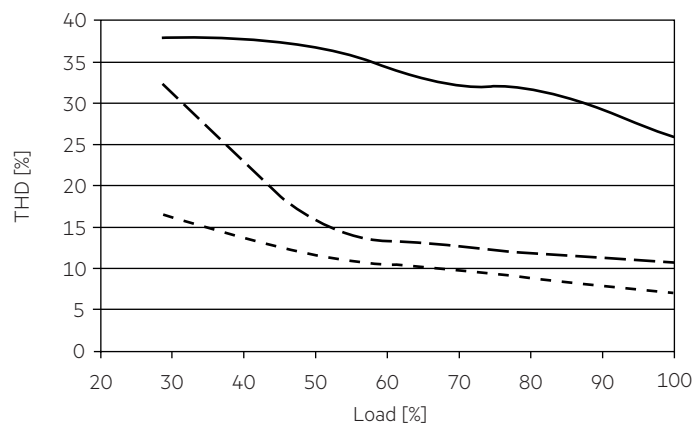

— 100 mA
 - - - 250 mA
 - · - · 400 mA

100 % load corresponds to the max. output power (full load) according to the table on page 2.

6. Emergency output factor EOFi

EM powerLED BASIC

Type	EM powerLED BASIC FX 213/233 Ip 75W 220V		EM powerLED BASIC FX 214/234 Ip 75W 220V		EM powerLED BASIC FX 215/235 Ip 75W 220V	
Article no.	89800598 / 89800601		89800599 / 89800602		89800600 / 89800603	
Cells	3 cells		4 cells		5 cells	
Output current	Min. LED load	Max. LED load	Min. LED load	Max. LED load	Min. LED load	Max. LED load
80 mA	39.50 %	13.50 %	55.00 %	19.00 %	70.00 %	24.00 %
100 mA	39.00 %	10.30 %	52.00 %	14.50 %	67.00 %	18.50 %
150 mA	32.00 %	7.00 %	42.00 %	9.90 %	56.00 %	12.50 %
200 mA	24.00 %	5.20 %	31.50 %	7.30 %	42.00 %	9.20 %
250 mA	19.20 %	4.10 %	25.00 %	5.80 %	33.50 %	7.40 %
300 mA	16.00 %	3.30 %	21.00 %	4.80 %	28.00 %	6.10 %
350 mA	13.80 %	3.10 %	18.00 %	4.10 %	24.00 %	5.30 %
400 mA	12.10 %	3.10 %	16.00 %	4.50 %	21.00 %	5.80 %

7. Functions

7.1 Function: adjustable current

The output current of the EM powerLED can be adjusted in a certain range. For adjustment there are two options available.

Option 1: I-select 2

By inserting a suitable resistor or third party resistor into the I-select 2 interface, the current value can be adjusted. The relationship between output current and resistor value can be found in the chapter "Accessories I-SELECT 2 Plugs".



Please note that the resistor values for I-select 2 are not compatible with I-select (generation 1). Installation of an incorrect resistor may cause irreparable damage to the LED module(s).

Resistors for the main output current values can be ordered from Tridonic (see accessories).

Option 2: ready2mains

Adjustment is done by the ready2mains Programmer and the corresponding configuration software (see ready2mains documentation).



Current adjustment can only be done five times over ready2mains. To program the EM powerLED a connected load is necessary that is within the operating window of the EM powerLED.

The priority for current adjustment methods is I-select 2 followed by ready2mains (lowest priority).

7.2 Short-circuit behaviour

In case of a short-circuit at the LED output the LED output is switched off. After restart of the EM powerLED the output will be activated again. The restart can either be done via mains reset or via interface ready2mains.

7.3 No-load operation

The EM powerLED will not be damaged in no-load operation. The output will be deactivated and is therefore free of voltage. If a LED load is connected the device has to be restarted before the output will be activated again.

7.4 Overload protection

If the output voltage range is exceeded the EM powerLED turns off the LED output. After restart of the EM powerLED the output will be activated again. The restart can be done via mains reset.

7.5 Overtemperature protection

The EM powerLED is protected against temporary thermal overheating. If the temperature limit is exceeded the output current of the LED module(s) is reduced. The temperature protection is activated approx. +5 °C above $t_{c\ max}$ (see page 2).

7.6 Forward voltage out of range

If the forward voltage is out of range the unit switches to shut down mode. After elimination of the short circuit a mains reset (SL off/on) is necessary.

8. Battery data

8.1 Battery selection

EM powerLED BASIC, 1 / 3 h

		Type	EM powerLED BASIC FX 213 lp 75W 220V	EM powerLED BASIC FX 233 lp 75W 220V	EM powerLED BASIC FX 214 lp 75W 220V	EM powerLED BASIC FX 234 lp 75W 220V	EM powerLED BASIC FX 215 lp 75W 220V	EM powerLED BASIC FX 235 lp 75W 220V
		Article no.	89800598	89800601	89800599	89800602	89800600	89800603
		Cells	3 cells	3 cells	4 cells	4 cells	5 cells	5 cells
		Duration	1 h	3 h	1 h	3 h	1 h	3 h
Technology and capacity	Design	Number of cells	Type	Article no.	Assignable batteries			
NiCd 4 Ah D cells	stick	1 x 3	Accu-NiCd 3A 55	28002773	•			
	stick	1 x 4	Accu-NiCd 4A 55	89800089		•		
	stick	1 x 5	Accu-NiCd 5A 55	28002774				•
	side by side	3 x 1	Accu-NiCd 3B 55	89800384	•			
	side by side	4 x 1	Accu-NiCd 4B 55	89800385		•		
	stick + stick	2 + 2	Accu-NiCd 4C 55	28002775		•		
	stick + stick	3 + 2	Accu-NiCd 5C 55	89800090				•
	remote box	1 x 3	Pack-NiCd 3D CON	89800389	•			
	remote box	1 x 4	Pack-NiCd 4D CON	89800390		•		
	remote box	1 x 5	Pack-NiCd 5D CON	28001181				•
NiMH 2.2Ah Cs cells	stick	1 x 3	Accu-NiMH 3A	28002088	•			
	stick	1 x 4	Accu-NiMH 4A	28002089		•		
	stick	1 x 5	Accu-NiMH 5A	28002090			•	
	side by side	5 x 1	Accu-NiMH 5B	28002093			•	
NiMH 4 Ah LA cells	stick	1 x 3	Accu-NiMH 4Ah 3A CON	89800441	•			
	stick	1 x 4	Accu-NiMH 4Ah 4A CON	89800442		•		
	stick + stick	2 + 2	Accu-NiMH 4Ah 4C CON	89800438		•		
	stick + stick	2 + 3	Accu-NiMH 4Ah 5C CON	89800439				•

8.2 Battery charge / discharge data

EM powerLED BASIC, 1 / 3 h

		EM powerLED BASIC FX 213 / 214 / 215 lp 75W 220V	EM powerLED BASIC FX 233 / 234 / 235 lp 75W 220V
Type			
Article no.		89800598 / 89800596 / 89800600	89800601 / 89800602 / 89800603
Cells		3 / 4 / 5 cells	3 / 4 / 5 cells
Duration		1 h	3 h
Battery charge time	Initial charge	24 h	
	Fast recharge	24 h	
	Trickle charge	continuously	
Charging current	Initial charge	105 mA	195 mA
	Fast recharge	105 mA	195 mA
	Trickle charge	70 mA	105 mA
Discharge current		850 – 960 mA	850 – 960 mA

8.3 Accu-NiCd**4.2 / 4.5 Ah**

International designation	KRMU 33/62
Battery voltage/cell	1.2 V
Cell type	D
Case temperature range to ensure 4 years design life	+5 °C to +55 °C
Max. short term battery case temperature (shorter than 1 month over the battery lifetime)	70 °C
Max. number discharge cycles	12 cycles per year plus 4 cycles during comissioning
Max. storage time	12 months

8.4 Accu-NiMH**2.2 Ah**

International designation	HRMU 23/43
Battery voltage/cell	1.2 V
Cell type	Cs
Case temperature range to ensure 4 years design life	+5 °C to +50 °C
Max. short term battery case temperature (shorter than 1 month over the battery lifetime)	70 °C
Max. number discharge cycles	4 cycles per year plus 30 cycles during comissioning
Max. storage time	12 months

4.0 Ah

International designation	HRMU 19/90
Battery voltage/cell	1.2 V
Cell type	LA
Case temperature range to ensure 4 years design life	+5 °C to +45 °C
Max. short term battery case temperature (shorter than 1 month over the battery lifetime)	70 °C
Max. number discharge cycles	4 cycles per year plus 30 cycles during comissioning
Max. storage time	12 months

8.5 Accupack-NiCd**4.5 Ah**

Battery voltage/cell	1.2 V
Cell type	D
Ambient temperature range to ensure 4 years design life tc point	+5 °C to +40 °C +45 °C
Max. short term battery case temperature (shorter than 1 month over the battery lifetime)	70 °C
Max. number discharge cycles	4 cycles per year plus 4 cycles during comissioning
Max. storage time	6 months

8.6 Accupack-NiMH**2.2 Ah**

Battery voltage/cell	1.2 V
Cell type	Cs
Ambient temperature range to ensure 4 years design life tc point	+5 °C to +35 °C +40 °C
Max. short term battery case temperature (shorter than 1 month over the battery lifetime)	70 °C
Max. number discharge cycles	4 cycles per year plus 4 cycles during comissioning
Max. storage time	12 months

4.0 Ah

Battery voltage/cell	1.2 V
Cell type	LAL
Ambient temperature range to ensure 4 years design life tc point	+5 °C to +35 °C +40 °C
Max. short term battery case temperature (shorter than 1 month over the battery lifetime)	70 °C
Max. number discharge cycles	4 cycles per year plus 4 cycles during comissioning
Max. storage time	12 months

For a higher battery temperature rating for NiMH 4 Ah refer to the EM converterLED xx MH/LiFePO4 product range.

8.7 Batteries

Connection method: 4.8 x 0.5 mm spade tag welded to end of cell

For stick packs this connection is accessible after the battery caps have been fitted.

To inhibit inverter operation disconnect the batteries by removing the connector from the battery spade tag.

For further information refer to corresponding battery datasheet.

8.8 Storage, installation and commissioning

Relevant information about storage conditions, installation and commissioning are provided in the battery datasheets.

9. Miscellaneous

9.1 Maximum number of switching cycles

All LED Drivers are tested with 50,000 switching cycles.
The actually achieved number of switching cycles is significantly higher.

9.2 Insulation and electric strength testing of luminaires

Electronic devices can be damaged by high voltage. This has to be considered during the routine testing of the luminaires in production.

According to IEC 60598-1 Annex Q (informative only!) or ENEC 303-Annex A, each luminaire should be submitted to an insulation test with 500 V_{DC} for one second. This test voltage should be connected between the interconnected phase and neutral terminals and the earth terminal.
The insulation resistance must be at least 2 MΩ.

As an alternative, IEC 60598-1 Annex Q describes a test of the electrical strength with 1500 V_{AC} (or 1.414 x 1500 V_{DC}). To avoid damage to the electronic devices this test must not be conducted.

9.3 Conditions of use and storage

Humidity: 5 % up to max. 85 %,
not condensed
(max. 56 days/year at 85 %)

Storage temperature: -40 °C up to max. +80 °C

The devices have to be acclimatised to the specified temperature range (t_a) before they can be operated.

9.4 Additional information

Additional technical information at www.tridonic.com → Technical Data

Guarantee conditions at www.tridonic.com → Services

Lifetime declarations are informative and represent no warranty claim.
No warranty if device was opened.