

FEATURES

- Up to 70% energy saving compared to standard CFL
- Long lifetime of 50,000 hours
- Dimmable when using triac dimmer
- 90° wide beam angle
- CCT: 3000K-4000K-5700K
- No UV/IR light
- IP54 from front cover
- Environment friendly, without Mercury or any other hazardous substances

APPLICATION

Designed for general lighting in office, supermarket, shop, school, hotel, etc. Also widely used for public areas, such as stairway, lobby, reception, corridors etc. (IP20/IP44 for indoor use only)



PRODUCT DIMENSION

*Typical Dimension (mm)

DSQ-3-13W-3C

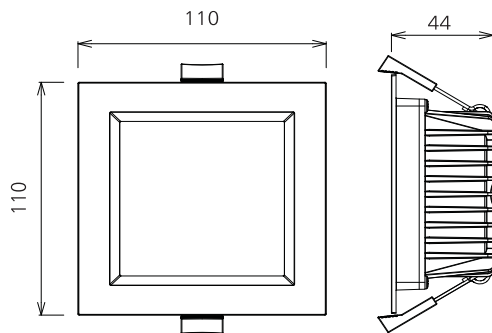

DSQ-6-18W-3C

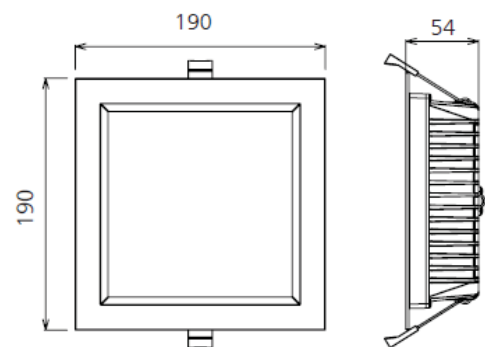

PHOTOMETRIC DATA

DSQ-3-13W 4000K

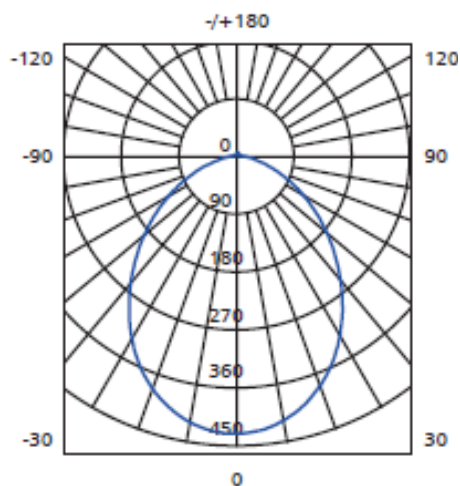

UNIT:cd
AVERAGE BEAM ANGLE(50%):90.8 DEG

DSQ-6-18W 4000K

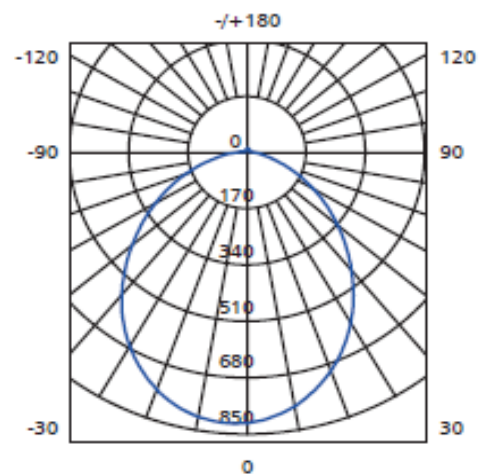

UNIT:cd
AVERAGE BEAM ANGLE(50%):95.5 DEG

Model No.	DSQ-3-13W 3C	DSQ-6-18W 3C
Power Consumption (W)	13± 0.5	18 ± 0.5
Luminaire Flux ± 5%(lm) 3000K	920	1440
Luminaire Flux ± 5%(lm) 4000K	930	1612
Luminaire Flux ± 5%(lm) 5000K	935	1656
Luminaire Flux ± 5%(lm) 5700K	940	1641
Beam Angle	90°	
Input Voltage (Vac)	100-240	100-240
Frequency (Hz)	50/60	50/60
Rated Input Current (A)	≤0.15	≤0.28
Power Factor (PF)	≥ 0.9	
Efficiency (%)	≥86	≥87
Net Weight /pc (kg)	0.4	1.11
Gross Weight/12pcs (kg)	12	14
Master Carton Dimension L x W x H (mm)	475x435x220	600x450.5x240

Note: The above specified lumen and system subject to changes without prior notice.

Triac Dim available upon request.

TECHNICAL SPECIFICATION

ELECTRICAL SYSTEM

Input Voltage	Protection Class	LED Driver
100-240Vac, 50/60Hz, PF > 0.9	Class II	Constant Current

Light Source	LED Type	(CRI)	Life Time Residual Flux	Optical System
SMD	2835	≥80	(L70), >40,000 hours	Reflector/Len

CERTIFICATION & COMPLIANCE TEST

- : EN 60958-1
- : EN 60598-2-2
- : EN 62471
- : EN 62031
- : EN 55015
- : EN 61000-3-2
- : EN 61000-3-3
- : EN 61547

FIXTURE/HOUSING

- Housing: Die Cast Aluminium
- PMMA Diffuser

OPTIONAL ACCESSORIES

- Triac
- DALI/ 1-10V Dimming Control