



PROJECT	LOCATION	LUMINAIRE REFERENCE
LIGHTING PROPOSAL		

PRODUCT DESCRIPTION

Crystal Wall lamp with a shielded LED source to reduce glare. Body material is ADC12 die-cast aluminum housing with heat tempered glass diffuser offering a uniform light output. Microwave sensor enable with Adjustable wattage for different setting.

TECHNICAL DATA

BRAND / MODEL	ELAP CRYSTAL SA-60W
HOUSING MATERIAL	ADC 12 Die Cast Aluminium
DIFFUSER MATERIAL	Glass Diffuser
LAMP TYPE	LED
LAMP WATTAGE	30W/40W/60W
LOSSES	Included or Tolerance +10% Max
INPUT VOLTAGE / HZ	220V-240V / 50Hz/60Hz
POWER FACTOR	>0.90
LUMEN	84000m
EFFICACY	140lm/w
COLOR TEMPERATURE	3000K/4000K/5000K
COLOR RENDERING INDEX	CRI >Ra80
BEAM ANGLE	TYPE IV
LIFE SPAN	50,000 hours
INGRESS PROTECTION RATING	IP65
IMPACT PROTECTION RATING	IK08
CUT-OUT (CEILING OPENING)	As shown
COUNTRY OF ORIGIN	Singapore
MANUFACTURE	China
WORKING TEMPERATURE	-20°C ~45°C
HOUSING COLOR	Bronze/Black
WEIGHT	3.4kg
CERTIFICATIONS	EN IEC 55015:2019+A11:2020 EN IEC 61000-3-2:2019+A1:2021 EN 61000-3-3:2013+A1:2019+A2:2021 EN 61547:2009, EN IEC 60598-2-1:2021; EN IEC 60598-1:2021+A11:2022; EN 62493:2015+A1:2022; EN IEC 62031:2020+A11:2021

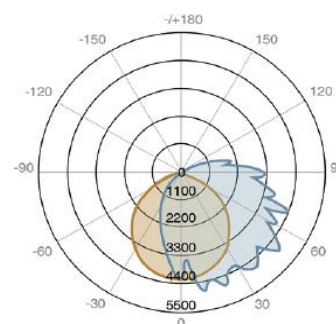

Type IV

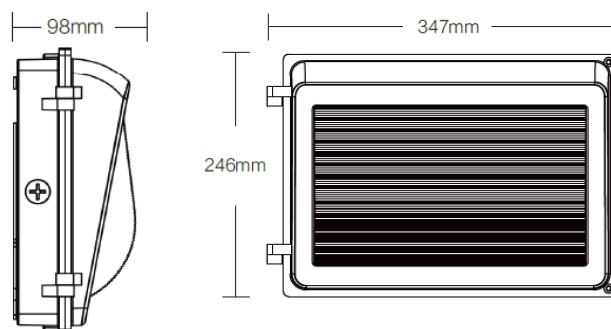

Optional Accessories:
Microwave sensor ,
Photocell Sensor