



GUANGDONG AOKLY GROUP CO., LTD

DINAMF(DIN140MF)maintenance-free battery

The battery has characteristics of excellent high-current discharge and is widely used in startup, ignition, lighting and other systems. It uses a grid made of lead-calcium alloy, which has the advantages of no need for maintenance and water addition and long storage time

Battery specification

VOLTAGE	12V
CAPACITY	140Ah @20hr to10.5V @25°C
RESERVE CAPACITY	250min @RC to10.5V @25°C
DIMENSION	509*180*195*220(mm)
INTERNAL RESISTANCE	4.3mΩ
USING TEMPERATURE	Discharge: -40°C~60°C Charging: -40°C~60°C Store: -40°C~60°C
BEST USING TEMPERATURE	10°C~30°C
CHARGING CURRENT	13A
CHARGING VOLTAGE(Using in car)	13.8V
MAX. CHARGING CURRENT	36A
MAX. DISCHARGING CURRENT	900A
TERMINAL TYPE	Standard terminal
CASE MATERIAL	PP
EXECUTIVE STANDARD	GB/T 5008.1-2013

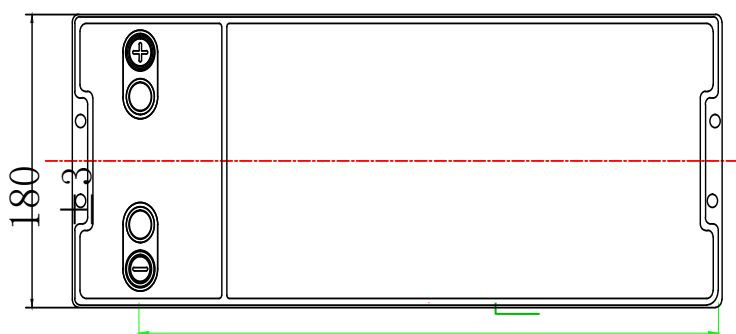
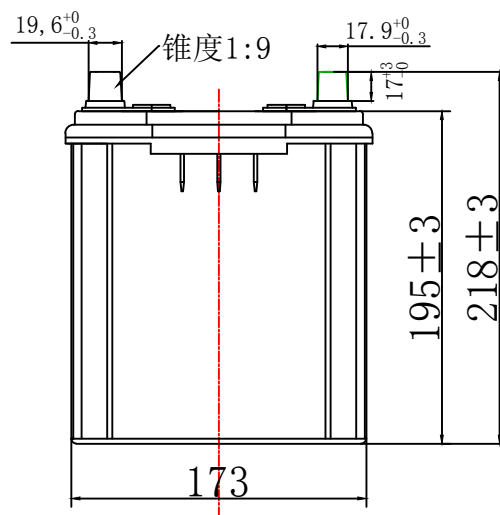
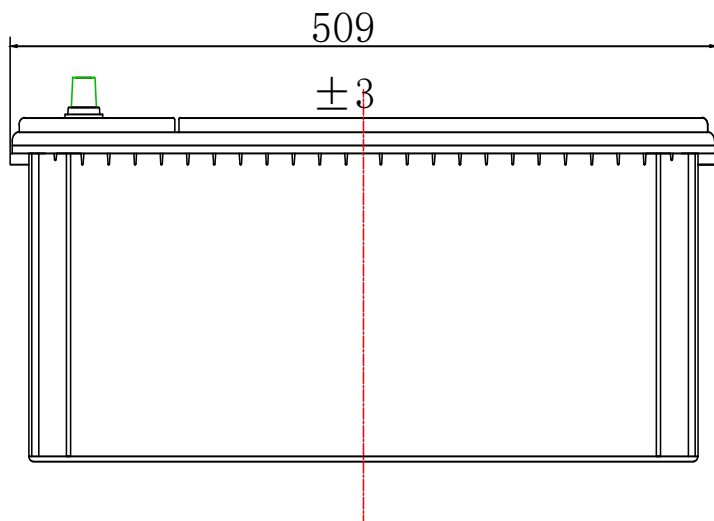

GUANGDONG AOKLY GROUP CO.,LTD

HUAQIAO INDUSTRIAL ZONE,DONGHUA
TOWN,YINGDE CITY, GUANGDONG
PROVINCE, CHINA.
TEL:86-20-86861998
FAX: 86-20-86878822
http: www.aokly-battery.com