

Constant current independent dimmable driver
DEL Series suffix d(DALI-2+pushDIM)



Features

- Support DALI-2+pushDIM dimming mode
- 10-level current output can be realized by DIP-switch
- Soft dimming and flicker-free at any brightness
- Using HPC patented technology, at any dimming level, the brightness of the lights is the same
- Dimming range 1~100%, output current accuracy 2%
- Standby power input<0.5W, meets the requirements of ErP certification
- High PF, high efficiency, low THD
- Screw-free and pressing type strain relief, supports thicker cables and is easier to install
- Independent input and output strain relief, stronger wiring
- Intelligent LED hot-plug protection function
- SELV and Class II design, suitable for use outside of the light
- Compliance with CE,ENEC,UKCA,RCM,CCC,DALI-2 and other certifications
- IP20 protection grade, indoor use
- Nominal life-time up to 100,000 h
- 5-year guarantee

Interfaces

- DALI-2(DALI-2 DT6)
- PUSH(pushDIM)

Functions

- Support central emergency application (dimming normal in DC input)
- Support self-contained emergency application
- Protective features (short-circuit, overload,no-load, hot plug-in protection)

Suitable for lights

- Suitable for lights with independent drivers such as downlights, spotlights, panel lights, etc
- Not suitable for lights with built-in drivers

Typical applications

- LED indoor lighting
- LED office lighting
- LED commercial lighting



Model coding rules of DEL series

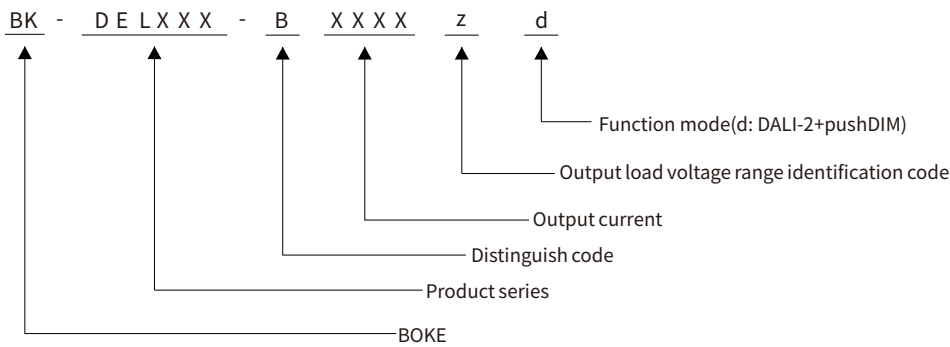

Function list

Model	suffix	Wired dimming		Connection cable
		DALI-2	pushDIM	
BK-DEL010-B BK-DEL022-B BK-DEL028-B BK-DEL030-B BK-DEL042-B BK-DEL060-B	d	√	√	1.5mm ² ×4 or 1.5mm ² ×2+1.5mm ² ×2 input wires
	DL	√	√	

* The description in this specification is only applicable to the products with the suffix **d** and the model are **DEL010-B, DEL022-B, DEL028-B, DEL030-B, DEL042-B** and **DEL060-B**.

Model list

Model	Input voltage	Output power	Output voltage	Output current	Dimension	Certifications
BK-DEL010-B0350Ad	200-240VAC/DC	11W MAX.	6-30/36/40/42VDC	0.10-0.35A	L117*W45.5*H24mm	CE, ENEC, UKCA, RCM, CCC, EL, DALI-2
BK-DEL010-B0350ADL	200-240VAC/DC	11W MAX.	6-30/36/40/42VDC	0.10-0.35A	L145*W45.5*H29mm	CE, ENEC, UKCA, RCM, CCC, EL, DALI-2
BK-DEL022-B0600Ad	200-240VAC/DC	23.1W MAX.	6-38/42VDC	0.225-0.60A	L117*W45.5*H29mm	CE, ENEC, UKCA, RCM, CCC, EL, DALI-2
BK-DEL022-B0600ADL	200-240VAC/DC	23.1W MAX.	6-38/42VDC	0.225-0.60A	L145*W45.5*H29mm	CE, ENEC, UKCA, RCM, CCC, EL, DALI-2
BK-DEL028-B0750Ad	200-240VAC/DC	28.5W MAX.	6-38/40/42VDC	0.30-0.75A	L117*W45.5*H29mm	CE, ENEC, UKCA, RCM, CCC, EL, DALI-2
BK-DEL028-B0750ADL	200-240VAC/DC	28.5W MAX.	6-38/40/42VDC	0.30-0.75A	L145*W45.5*H29mm	CE, ENEC, UKCA, RCM, CCC, EL, DALI-2
BK-DEL030-B0800Ad	200-240VAC/DC	30.4W MAX.	6-38/40/42VDC	0.25-0.80A	L103*W68.5*H30.5mm	CE, ENEC, UKCA, RCM, CCC, EL, DALI-2
BK-DEL030-B0800ADL	200-240VAC/DC	30.4W MAX.	6-38/40/42VDC	0.25-0.80A	L140*W71*H30mm	CE, ENEC, UKCA, RCM, CCC, EL, DALI-2
BK-DEL042-B0800Bd	200-240VAC/DC	38.4W MAX.	6-48VDC	0.25-0.80A	L103*W68.5*H30.5mm	CE, ENEC, UKCA, RCM, CCC, EL, DALI-2
BK-DEL042-B0800BDL	200-240VAC/DC	38.4W MAX.	6-48VDC	0.25-0.80A	L140*W71*H30mm	CE, ENEC, UKCA, RCM, CCC, EL, DALI-2
BK-DEL042-B1100Ad	200-240VAC/DC	42W MAX.	6-38/40/42VDC	0.45-1.10A	L103*W68.5*H30.5mm	CE, ENEC, UKCA, RCM, CCC, EL, DALI-2
BK-DEL042-B1100ADL	200-240VAC/DC	42W MAX.	6-38/40/42VDC	0.45-1.10A	L140*W71*H30mm	CE, ENEC, UKCA, RCM, CCC, EL, DALI-2
BK-DEL060-B2000Ad	200-240VAC/DC	61.2W MAX.	6-30/32/34/36/38/40/42VDC	0.80-2.00A	L123.5*W79.5*H31mm	CE, ENEC, UKCA, RCM, CCC, EL, DALI-2
BK-DEL060-B2000ADL	200-240VAC/DC	61.2W MAX.	6-30/32/34/36/38/40/42VDC	0.80-2.00A	L160*W80.8*H30mm	CE, ENEC, UKCA, RCM, CCC, EL, DALI-2

* The description in this specification is only applicable to the products with the suffix **d** and the model are **DEL010-B, DEL022-B, DEL028-B, DEL030-B, DEL042-B** and **DEL060-B**.

Technical data

Product model	BK-DEL030-B0800Ad
Output parameters	
Regulation method	Constant Current
Rated output current range	0.25-0.8A
Rated output voltage range	6-38/40/42VDC
Rated output power	30.4W Max
Output current adjustment	DIP S.W(16 levels)
Output current ripple LF	±2%
Output current accuracy	±2%
Linear regulation	±1%
Load regulation	±1%
No load output voltage	50VDC
Flicker-free(typical)	Flickering percent(IEEE 1789)=0.757%, Flicker index(IEEE 1789)=0.002, Pst LM = 0.002, SVM = 0.003, (The above parameters are obtained from testing the panel lights)
Input parameters	
Rated input voltage range	200-240VAC 200-240VDC
Input voltage range	180-264VAC 200-264VDC
Input voltage shock	<380 V AC
Input current	<0.18A (Rated input voltage)
Input frequency	0/50/60Hz
Input PF/Input DF	PF: 0.97, DF: 0.98 ,see the electrical values below for details
Input THD	5% ,see the electrical values below for details
Efficiency(Max)	89% ,see the electrical values below for details
In-rush current	3.95A peak ,180us duration(50 % Ipeak), see the description below for details
Start/Switchover/Turn off	<0.7s(AC start),<0.7s(DC start),<0.3s(AC/DC switchover),<0.5s(Turn off)
Switching cycles	> 50,000 switching cycles
Power consumption	Full load(Pin):34.2W, No load(Pno): N/A, On stand-by(Psb) : <0.5W, Network stand-by(Pnet) : N/A
Safety	
Withstand voltage	I/P-O/P:3750V AC, I/P-DALI: 1500V AC, O/P-DALI: 1500V AC.
Mains surge capability	L-N:2KV(Performance criterion:A)
Leakage current	0.36mA (230V AC & Full load)
Isolation resistance	I/P-O/P:100MΩ/500Vdc/25°C/70% RH
Control interface	
DALI dimming port	Voltage range: 9.5-22.5V, typical 16V, interface current consumption: 1.8mA
pushDIM dimming port	Voltage range: 180-264V 47/63Hz
1-10V 3in1 dimming port	N/A
Auxiliary power supply	N/A
Dimming range	1%-100%
Dimming drive mode	AM(amplitude modulation)
Emergency support	
Central emergency system	Supported(dimming normal in DC input)
Self-contained emergency	Supported
Environment & Life time	
Operating temperature	Ta=-20-45°C
Case temperature	Tc=90°C
Operating humidity	5-85% RH, not condensed
Storage temp./humidity	-40-80°C, 5-85% RH, not condensed
IP grade	IP20
MTBF	500,000H,MIL-HDBK-217F(25°C)
Life-time	Nominal life-time up to 100,000 h, see the description below for details
Vibration resistant	10~500Hz,5G 12min./1cycle,period for 72min. each along X,Y,Z axes
Acoustic Noise	<25dB(30cm, Normal operation)
Environmental protection	RoHS
Certifications and standards	
Certification	CE, ENEC, UKCA, RCM, CCC, EL, DALI-2
Safety	EN61347-1, EN61347-2-13, EN62384
EMC	EN55015, EN61000-3-2 , EN61000-3-3, EN61000-4-2,3,4,5,6,8,11, EN61547
DALI-2	IEC 62386-101(DALI-2), IEC 62386-102(DALI-2), IEC 62386-207(DALI-2)
EL	Compatible IEC 61347-2- 13 Annex J , compatible with EN 60598-2-22 and EN 50172
RF	N/A

Remarks

- 1.By default, all parameter are measured at 230VAC input, full load and 25°C of ambient temperature.
- 2.The driver can not be installed inside the light. when the driver is used with the light, the EMC of the whole light needs to be tested.

Electrical values

BK-DEL030-B0800Ad

Operating window

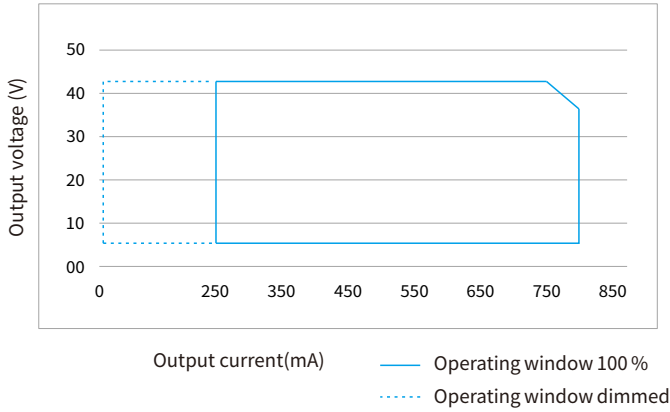

Operating window

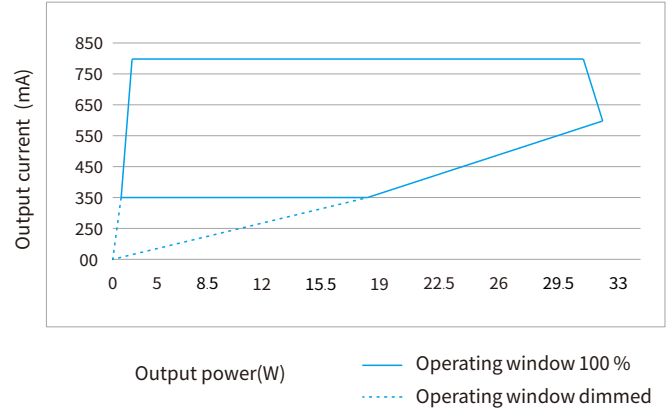

Efficiency vs load

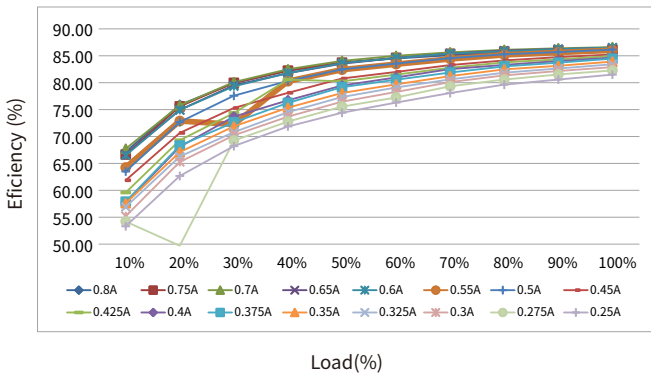

THD vs. Load

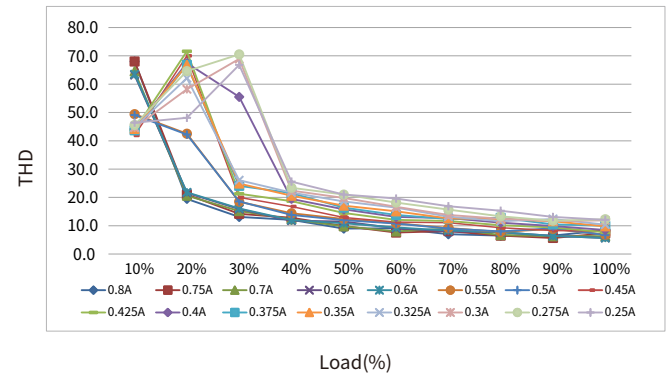

Power factor vs. Load

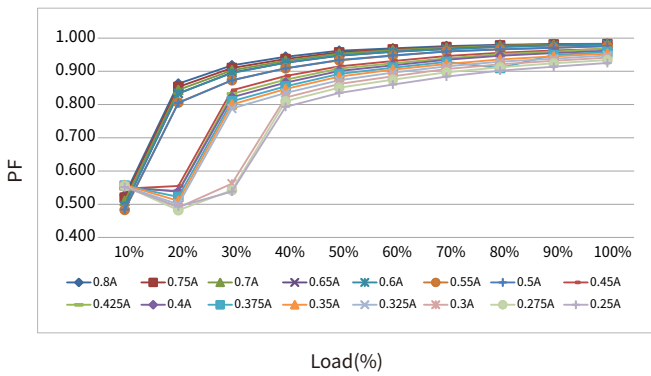

Displacement factor vs. Load

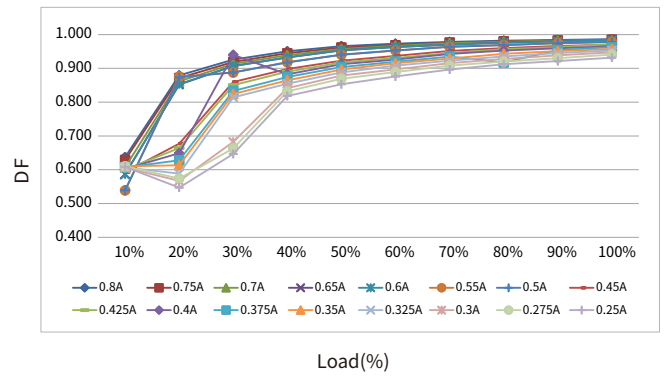

Expected life-time

Life-time vs. case temperature

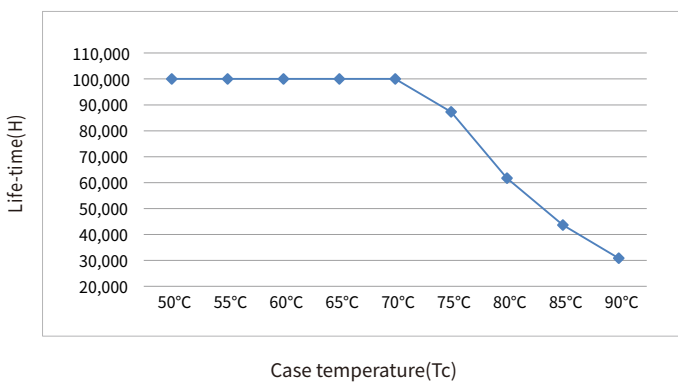

-The life-time of the LED driver is shown in the figure above (calculated based on the 90% survival rate).

- The relation of t_c to t_a temperature depends also on the luminaire design.

Surge

Model	Ipeak	Twidth	Condition	Relative number of MCB/pcs														
				B10	B13	B16	B20	B25	C10	C13	C16	C20	C25	D10	D13	D16	D20	D25
BK-DEL010-B0350Ad	3.79A	170us	AC 230V, Full load, Cold start, $T_a \leq 30^\circ\text{C}$, MCB is not installed side by side	98	127	157	196	245	119	154	190	237	296	119	154	190	237	296
BK-DEL022-B0600Ad	6.28A	206us		48	62	77	96	120	57	74	91	113	142	57	74	91	113	142
BK-DEL028-B0750Ad	6.25A	212us		45	59	73	91	113	45	59	73	91	113	45	59	73	91	113
BK-DEL030-B0800Ad	3.95A	180us		46	60	73	92	114	46	60	73	92	114	46	60	73	92	114
BK-DEL042-B0800Bd	7.9A	180us		36	47	58	73	91	36	47	58	73	91	36	47	58	73	91
BK-DEL042-B1100Ad	7.9A	176us		33	42	52	65	81	33	42	52	65	81	33	42	52	65	81
BK-DEL060-B2000Ad	9.1A	174us		23	29	36	45	57	23	29	36	45	57	23	29	36	45	57

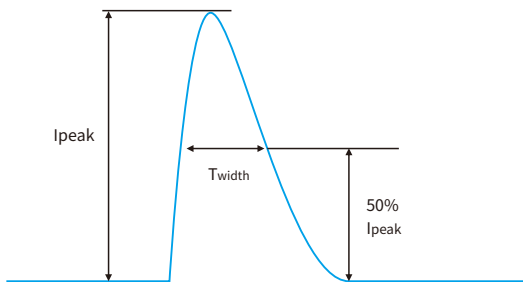

Remarks

- The number of drives mounted under different MCBs in the table is the maximum value. Please do not exceed this number during installation.
- Calculation uses typical values from ABB series S200 as a reference.
- Different brands and models of miniature circuit breakers, the number of drives mounted will be slightly different.
- If the ambient temperature of the MCB installation exceeds 30°C or multiple MCBs are installed side by side, the number of drives mounted will be reduced and the calculation needs to be recalculated.
- Electrician's usually consider Type B for household lighting and Type C for commercial lighting application.

Functions

Output short-circuit behaviour

- The LED driver will not be damaged in short-circuit operation. After removing the short-circuit, the output will be normal.

Output no-load operation

- The LED driver will not be damaged in no-load operation.
- The output will be deactivated and is therefore free of voltage.
- If a LED load is connected, the device has to be restarted before the output will be activated again.

Output overload protection

- The LED driver turns off the output if the output voltage range is exceeded.
- After restart of the LED driver the output will be activated again.

Output hot plug-in

In the following two cases, the LED driver will automatically turn off the output to protect the LED

- When the driver is powered on first and the LED is connected later.
- When the driver is powered on, disconnected and connected again.
- After restart of the LED driver the output will be activated again.

Driver restart method

There are two ways to restart the device:

- Through the AC input port: disconnect the AC of the driver and power it again.
- Through dimming interface.

DALI: send "OFF" command first, then send "MAX" command.

pushDIM: short press pushbutton two times, then long press pushbutton.

Insulation between circuits

Isolation	Input	Output	Case	DALI	PUSH
Input	-	Double	Double	Basic	-
Output	Double	-	Basic	Double	Double
Case	Double	Basic	-	Double	Double

DALI dimming application

Wiring diagram

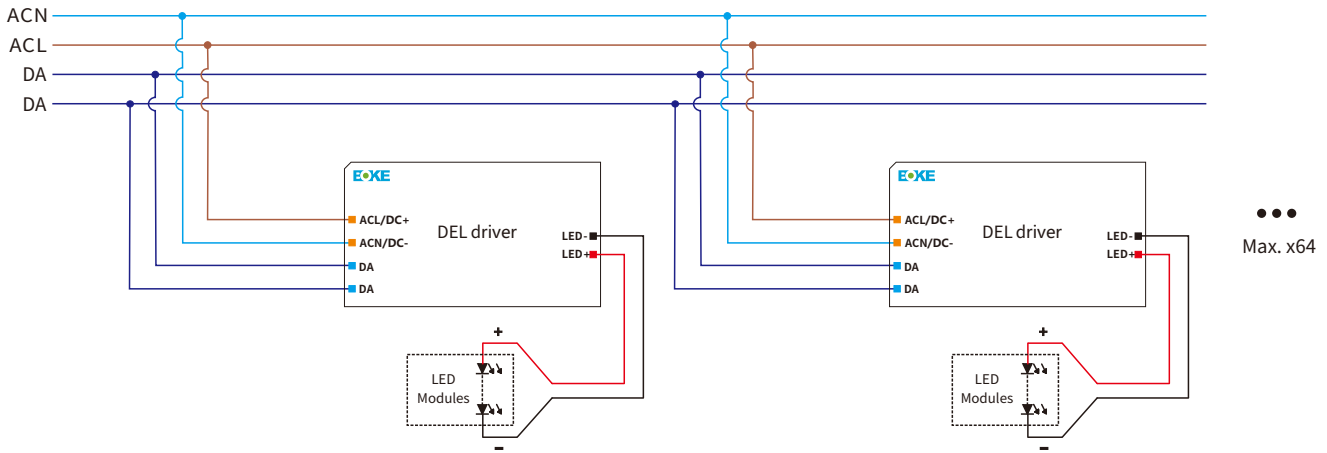

Switch to the DALI dimming mode

- After installation according to the wiring diagram of DALI dimming application, the driver will automatically switch to the DALI control mode after receiving any DALI command.

Remarks:

- Standard DALI control line voltage range: 9.5V to 22.5V, type 16V.
- The two DALI control lines polarity-reversible.
- Max. 64 DALI drivers per DALI control line.
- The maximum distance length of the DALI control line is 300m at $2 \times 1.5\text{mm}^2$.
- DALI bus can be wired together with any mains voltage cables, but separate wiring is recommended.
- The configuration parameters of the driver can be set through the DALI configuration tool or DALI application controller during installation, such as setting device address, group address, power-on level, bus-failure level, scene level, fade time, dimming curve, etc.

Please refer to the table below

Cable size	Distance
$2 \times 0.50\text{mm}^2$	max.100m
$2 \times 0.75\text{mm}^2$	max.150m
$2 \times 1.00\text{mm}^2$	max.200m
$\geq 2 \times 1.50\text{mm}^2$	max.300m

Power-on level :

When the driver is in DALI-2 dimming mode, the factory default level after each power-on is the brightest.

The power-on level can be set through the DALI configuration tool or DALI application controller during installation, and can be set to memory or fixed any brightness (such as off, darkest, 50%, etc.).

Note: The recommended setting for the default factory power-on level of the DALI-2 driver is the brightest in the DALI-2 standard.

Dimming curve

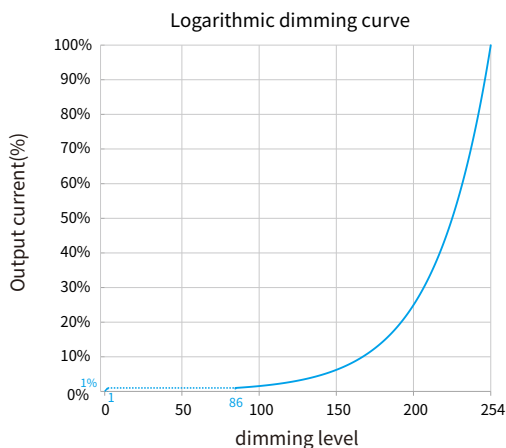

Remarks: The dimming curve can be selected by DALI configuration. The default is logarithmic dimming curve.

pushDIM dimming application

Wiring diagram

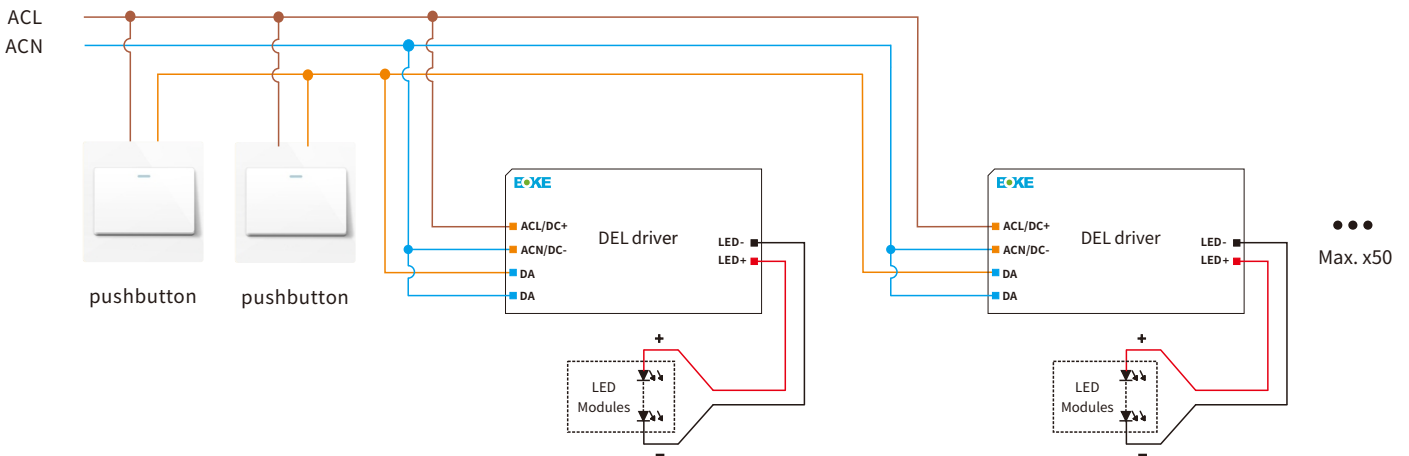

Switch to the pushDIM dimming mode

- After installation according to the wiring diagram of pushDIM dimming application, short press the pushbutton 1 times or short press the pushbutton 5 times quickly within 3s , the driver will automatically switch to the pushDIM dimming mode.

Remarks:

Max. 50 drivers per pushDIM control line.

Turn on or turn off: short press pushbutton for 0.2-1s.

Dimming: long press pushbutton for 1-5s.

Power on status: after power on, the light state will be the same as the lighting on state.

If the light is on before power on, the light will be on after power on again, brightness will be the same as the last lighting on brightness.

If the light is off before power off, the light will be off after power on again, short press the pushbutton, then the light will be on, the brightness will be the same as the last brightness.

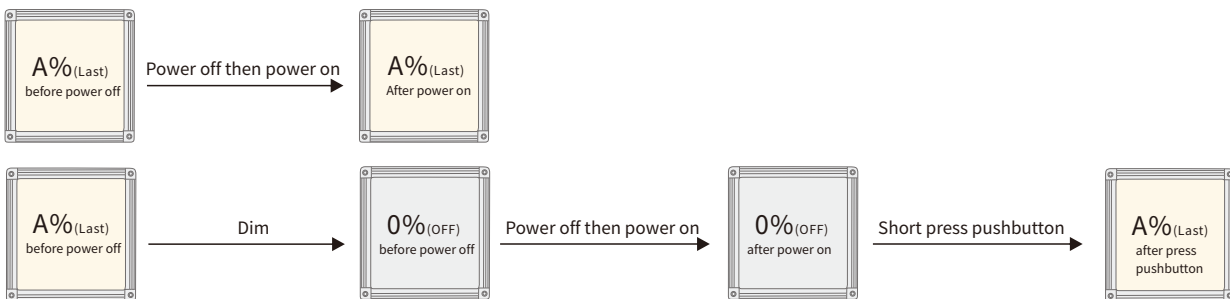

Multiple lights synchronize control operation

method 1:

Step 1: long press the pushbutton, confirm each light is on.

Step 2: short press the pushbutton, confirm each light is off.

Step 3: long press the pushbutton, confirm each light is from darkest to brightest and all the lights are synchronous.

method 2:

- Long press the pushbutton 15s, all lights output to the brightest state.